

Construct validity of the Anxiety Sensitivity Index-3 in clinical samples

Kemper, C. J. ^{a*}, Lutz, J. ^b, Bähr, T. ^c, Rüdgel, H. ^d, & Hock, M. ^e

^{a*} GESIS – Leibniz Institute for the Social Sciences, Mannheim

^b University of Potsdam

^c University of Mainz

^d Psychosomatic Clinic St. Franziska-Stift, Bad Kreuznach

^e University of Bamberg

The final, definitive version of this paper has been published in *Assessment*, Vol 19 /

Issue 1, 03/2012 by SAGE Publications Ltd, All rights reserved. ©

* Corresponding author: Christoph J. Kemper, B 2.1, P.O. Box 12 21 55, 68072 Mannheim, Germany. E-mail: christoph.kemper@gesis.org, Telephone: +49 (0)621 1246 501, Fax: +49 (0)621 1246 500.

Abstract

Using two clinical samples of patients, the presented studies examined the construct validity of the recently revised Anxiety Sensitivity Index 3 (ASI-3). Confirmatory factor analyses established a clear three-factor structure that corresponds to the postulated subdivision of the construct into correlated somatic, social, and cognitive components. Participants with different primary clinical diagnoses differed from each other on the ASI-3 subscales in theoretically meaningful ways. Specifically, the ASI-3 successfully discriminated patients with anxiety disorders from patients with non-anxiety disorders. Moreover, patients with panic disorder or agoraphobia manifested more somatic concerns than did patients with other anxiety disorders and patients with non-anxiety disorders. Finally, correlations of the ASI-3 scales with other measures of clinical symptoms and negative affect substantiated convergent and discriminant validity. Substantial positive correlations were found between the ASI-3 Somatic Concerns and body vigilance; between Social Concerns and fear of negative evaluation and socially inhibited behavior; and between Cognitive Concerns and depression symptoms, anxiety, fear of negative evaluation, and subjective complaints. Moreover, Social Concerns correlated negatively with dominant and intrusive behavior. Results are discussed with respect to the contribution of the ASI-3 to the assessment of anxiety-related disorders.

Keywords: anxiety sensitivity; Anxiety Sensitivity Index; ASI-3; construct validity; reliability; clinical sample; factor structure

Construct validity of the ASI-3 in clinical samples

Anxiety Sensitivity (AS) denotes the tendency to fear anxiety-related sensations, arising from beliefs that these sensations carry a risk for aversive consequences (Reiss, 1991). AS is a stable but malleable multidimensional personality trait (Armstrong, Khawaja, & Oei, 2006; Schmidt et al., 2007), encompassing fears of somatic, social, and cognitive consequences of anxiety (Reiss, 1991; Taylor et al., 2007). Reiss (1991) proposed that AS may act as a dispositional amplifier of fear, anxiety, and panic reactions, thereby contributing to the development and maintenance of anxiety pathology. Subsequent research demonstrated that AS is indeed substantially related to state and trait measures of fear, anxiety, and behavioral avoidance in clinical as well as in nonclinical samples (Eifert, Zvolensky, Sorrell, Hopko, & Lejuez, 1999; Reiss, Peterson, Gursky, & McNally, 1986; Schmidt & Mallott, 2006; Taylor, 1996; Wilson & Hayward, 2006). Importantly, it has been shown that AS is more than a mere correlate of psychopathology by predicting the incidence of DSM-IV Axis I pathology, particularly panic symptoms and panic disorder in adolescents and adults (Plehn & Peterson, 2002; Schmidt, Zvolensky, & Maner, 2006; Schmidt et al., 2010). Currently, AS is seen as a prominent cognitive risk factor in the pathogenesis of anxiety (Schmidt, 1999).

The important role of AS in anxiety pathology becomes evident by comparing AS scores between patients with different clinical diagnosis or between persons with vs. without diagnosis. In a recent meta-analysis, Olatunji and Wolitzky-Taylor (2009) reported greater AS among anxiety and mood disorder patients compared to nonclinical controls, $d = 1.61$ and $d = .71$ respectively. Elevated levels of AS can be found for patients with panic disorder and agoraphobia (Reiss et al., 1986), social phobia and specific phobia (Sandin, Chorot, & McNally, 1996), obsessive compulsive disorder (Calamari, Rector, Woodard, Cohen, & Chik, 2008), posttraumatic stress disorder (Leen-Feldner, Feldner, Reardon, Babson, & Dixon, 2008), and depression (Otto, Pollack, Fava, Uccello, & Rosenbaum, 1995). Compared to patients with other anxiety disorders or nonclinical controls, patients with panic disorder

Construct validity of the ASI-3 in clinical samples

and/or agoraphobia usually have the highest AS scores (Deacon & Abramowitz, 2006; Taylor et al., 2007).

AS is not a unitary construct as originally proposed by Reiss (1991). Actually, numerous studies suggest that AS is best conceptualized as a hierarchical construct that is composed of three lower order dimensions: Somatic Concerns, Social Concerns, and Cognitive Concerns (Taylor et al., 2007; Zinbarg, Barlow, & Brown, 1997). These lower order dimensions seem to be of different impact in the development and maintenance of anxiety problems as each dimension is associated with thematically related anxiety psychopathology. For example, the factor Somatic Concerns is most strongly correlated with phenomena pertaining to panic and agoraphobia. Zinbarg, Brown, Barlow, and Rapee (2001) found that this factor is the only one of the three lower order factors that contributes to relations with fear responses to laboratory panic challenges. Moreover, measures of this factor correlate substantially with body vigilance (Zvolensky & Forsyth, 2002) and a diagnosis of panic disorder and/or agoraphobia (Taylor et al., 2007). In contrast, the AS factor Social Concerns is substantially correlated with trait measures covering interpersonal behavior such as fear of negative evaluation and extraversion (Kemper, Ziegler, & Taylor, 2009) and a diagnosis of social phobia (Taylor et al., 2007). Finally, the Cognitive Concerns factor shows moderate to high correlations with measures of depression (Armstrong et al., 2006) and seems to be a relatively nonspecific measure of general distress (Taylor, Koch, Woody, & McLean, 1996).

The majority of studies conducted during the last 25 years focus on the latent dimensionality of the AS construct. These studies suggest that AS is a multidimensional and hierarchically organized construct with one general factor and three to four lower order factors which seem differentially related to various forms of psychopathology. Besides this dimensional approach some researchers have applied other approaches in AS structural research in order to test a conjecture first formulated by Taylor (1999) and later adopted and

Construct validity of the ASI-3 in clinical samples

elaborated by Bernstein and colleagues (e.g. Bernstein et al., 2007). These authors suggest that the latent structure of AS might not be dimensional but categorical or a mixture thereof and that only one of two postulated latent classes is uniquely associated with vulnerability for anxiety psychopathology. If this conjecture was empirically supported, its impact on our understanding of the role AS plays in the etiology of psychopathology would be strong. Bernstein and colleagues applied elaborate statistical methods, e.g. coherent cut kinetic taxometric methods (CCK; Waller & Meehl, 1998), a mixture of CCK and factor analytic methods, and factor mixture modeling (FMM; Muthén, 2008), to support their claim. They were able to present findings from demographically and geographically diverse samples (for an overview see Bernstein et al., 2010) corroborating their claim that “AS has a taxonic (two-class) latent structure, and that each class has a unique multidimensional factor structure” (Bernstein et al., 2010, p. 527). However, their claim concerning the categorical two-class structure is not uncontroversial. Their position is currently challenged by several researchers who could not find evidence for the two postulated substantive AS classes (Asmundson, Weeks, Carleton, Thibodeau, & Fetzner, 2011; Broman-Fulks et al., 2008; Broman-Fulks et al., 2010; Kemper, 2010). This issue is far from being settled as both positions seem supported by comprehensive evidence.

However, measures of the construct that were developed in the past (for an overview see Peterson & Plehn, 1999) rest on the assumption that the latent AS structure is dimensional. Between 1986 and 2009, the Anxiety Sensitivity Index (ASI, Reiss et al., 1986) was the most frequently used measure of the construct (Kemper, 2010). Due to criticism pertaining to aspects of its psychometric quality the ASI was revised twice. In 1998, Taylor and Cox proposed the Anxiety Sensitivity Index-Revised (ASI-R) as a broad measure of AS and its lower-order dimensions. Because of its unstable factor structure (cf. Taylor et al., 2007) another revision took place. The most recent version, the Anxiety Sensitivity Index-3 (ASI-3) was proposed by Taylor and colleagues in 2007.

Construct validity of the ASI-3 in clinical samples

The 18 item ASI-3 assumes a hierarchical three-factor structure of the construct and yields measures of Somatic Concerns (e.g., “It scares me when my heart beats rapidly”), Social Concerns (e.g., “It is important for me not to appear nervous”), and Cognitive Concerns (e.g., “When I cannot keep my mind on a task, I worry that I might be going crazy”) for the first order level, and Global AS for the second order level. Some studies confirming the psychometric quality have been conducted so far using nonclinical samples. The three-factor hierarchic structure of the ASI-3 was confirmed in several geographically diverse North American samples (Taylor et al., 2007), thereby corroborating the consensus reached among AS researchers on the structure of the ASI (Zinbarg et al., 1997). Invariance of the internal structure between different countries was supported (Kemper et al., 2009). Further evidence concerning the construct validity of the ASI-3 was obtained in these studies as well as in others (e.g. Osman et al., 2010). Notably, the ASI-3 was found to be superior to its predecessors ASI and ASI-R. Taylor et al. (2007) demonstrated that the ASI-3 measures the construct more precisely – the ASI-3 has a higher reliability and construct validity than the ASI. In contrast to the ASI-R, the internal structure of the ASI-3 is stable across diverse samples. According to these results, the ASI-3 may be considered a reliable and valid measure of the most robust dimensions of the AS construct.

In the upcoming years the ASI-3 might well become the standard tool of AS assessment. Thus, further research on its psychometric quality is necessary. The construct validity of the ASI-3 was already demonstrated in several nonclinical samples (Kemper et al., 2009; Osman et al., 2010). However, the question whether the ASI-3 is a useful assessment tool in clinical psychology research and a feasible screening instrument in applied settings has been addressed only once so far. In their large psychometric study of the ASI-3, Taylor and colleagues (2007) also analyzed a subsample of patients. These authors obtained first evidence for the construct validity of the ASI-3 in a clinical context by comparing groups differing in primary diagnosis on ASI-3 subscale scores (criterion-related validity). In order to

Construct validity of the ASI-3 in clinical samples

further advance knowledge on the usefulness of the ASI-3 for clinical research and assessment, we addressed different aspects of construct validity. Construct validity of the ASI-3 was assessed in two samples of patients with anxiety or mood disorders by (a) testing the three-factor hierarchical structure proposed by Taylor and colleagues (2007) (factorial validity), (b) examining relations of ASI-3 scores with psychopathology-related constructs (convergent and discriminant validity), and (c) comparing ASI-3 scores of patients with different clinical diagnoses (criterion-related validity; cf. Taylor et al., 2007).

Four sets of theoretical expectations pertaining to the four scales yielded by the ASI-3 – Somatic, Social, Cognitive Concerns and Global AS, guided the validation process. (1) The ASI-3 measure of Global AS (GAS) should differentiate between patients with anxiety disorder and patients with non-anxiety disorders since patients with anxiety disorders have elevated levels of AS compared to other patients or persons without a clinical diagnosis (Olatunji & Wolitzky-Taylor, 2009).

Particularly, patients with panic disorder fear anxiety-related sensations due to their assumed aversive somatic consequences, e.g. heart attack. Thus, (2) the Somatic Concerns subscale of the ASI-3 (SOM) should allow for a differentiation of patients with panic disorder and/or agoraphobia and patients with non-anxiety disorders or other anxiety disorders (Taylor et al., 2007). Moreover, substantial correlations of the SOM subscale with measures of body vigilance and symptom burden should be observable in clinical samples as (a) high AS persons indicate a higher vigilance for somatic symptoms in self-reports (Zvolensky & Forsyth, 2002), and (b) a higher interoceptive accuracy concerning diverse somatic symptoms and processes compared to persons with low AS (Richards & Bertram, 2000).

The Social Concerns subscale of the ASI-3 (SOC) captures concerns and fear of social consequences of publicly observable anxiety reactions, e.g. ridicule. Persons who experience problems in their interpersonal relationships, for example people who are shy, insecure, introverted or socially avoidant, may be particularly prone to the fear that their anxiety

Construct validity of the ASI-3 in clinical samples

symptoms could be observed and evaluated by others in a negative way. Thus, (3) substantial correlations should be obtained between SOC and measures of interpersonal problems, fear of negative evaluation, or social phobia (cf. Kemper et al., 2009, Naragon-Gainey, 2010).

The Cognitive Concerns subscale (COG) measures fears that symptoms of anxiety could lead to catastrophic cognitive consequences. “Anxiety disorders have been found to be associated with particular forms of cognitive concerns” (Taylor et al., 2007, p. 185). For example, panic disorder seems to be associated with strong fears of catastrophic consequences (e.g. loss of control) which might arise from cognitive phenomena such as derealization. GAD was found to be associated with the harmful effects of uncontrollable worry (cf. Taylor et al., 2007). Patients with depressive episode seem particularly prone to another form of cognitive concerns – rumination (Nolan-Hoecksema, 2000). Taken together, these results suggest that many anxiety and mood disorders involve different forms of cognitive concerns. Findings from the AS literature corroborate this suggestion by reporting substantial correlations between AS Cognitive Concerns and measures of anxiety or mood disorders or elevated subscale scores of these diagnostic groups (Deacon & Abramowitz, 2006; Naragon-Gainey, 2010; Otto et al., 1995; Rector, Szacun-Shimizu, & Leybman, 2007; Taylor et al., 2007). Thus, (4) we expected to find substantial differences between patients diagnosed with an anxiety or mood disorder compared to patients without such a diagnosis (non-anxiety non-mood disorder). Moreover, we expected substantial correlations between COG and measures of depression symptoms (Naragon-Gainey, 2010).

Method

Participants

Two clinical samples were used in the following analyses. Sample 1 consisted of 514 patients receiving cognitive-behavioral or psychodynamic treatment at a psychotherapeutic inpatient unit in Germany (cf. Watzke et al., 2010). Patients who fulfilled the criteria for at least one mental disorder according to the International Statistical Classification of Diseases and

Construct validity of the ASI-3 in clinical samples

Related Health Problems 10th Revision (ICD-10) Chapter V (WHO, 1992) with a primary diagnosis of neurotic, stress-related, and somatoform disorders (F41-49) or mood disorders (F30-39) were recruited. These clinical diagnoses were chosen for the present investigation as these patients are affected by elevated AS scores (Olatunji & Wolitzky-Taylor, 2009). Sample 1 did not contain persons with diagnoses F10-19 as persons with a primary diagnosis related to substance abuse are not routinely treated at the clinic. Sample 1 was 73 % female, with a mean age of 47 years ($SD = 10$ years). In terms of the International Standard Classification of Education (ISCED) 44 % had completed lower secondary education and 38 % upper secondary education. A total of 21 % were single, 46 % were married, and the remaining were separated, widowed, or divorced. Fifty-five percent received some form of psychopharmacological treatment (anti-depressants, anxiolytics, neuroleptics, etc.). All diagnoses were assessed clinically and were based on ICD-10 criteria (for details on the diagnostic process see below). Primary diagnoses in terms of severity or relevance to treatment¹ were: depressive disorders (F33.0 - F33.9, $n = 248$), adjustment disorders (F43.2, $n = 118$), agoraphobia and panic disorder with/or without agoraphobia (F40.0, F41.0, $n = 38$), mixed anxiety-depression (F41.2, $n = 17$), somatoform disorders (F45.1/3, $n = 16$), dysthymia (F34.1, $n = 14$), posttraumatic stress disorder (F43.1, $n = 13$), complex chronic pain disorder (F45.4, $n = 13$), generalized anxiety disorder (F41.1, $n = 11$), other specified neurotic disorders (F48.8, $n = 9$), social phobia (F40.1, $n = 5$), obsessive-compulsive disorder (F42.-, $n = 6$), other anxiety disorders (F41.8-9, $n = 2$), dissociative disorders (F44.-, $n = 3$), bipolar disorder (F31.-, $n = 1$).

Sample 2 was composed of 75 out-patients of various psychotherapists in the Rhine-Main Metropolitan Region of Germany receiving cognitive-behavioral treatment at the time of assessment. 84 % of the sample was female. Mean age of patients was 39 years ($SD = 12$ years). 57 % had completed lower secondary education and 43 % upper secondary education. Almost half of the sample (49 %) was married, 37 % were single, and the remaining were

Construct validity of the ASI-3 in clinical samples

separated or divorced. Inclusion criteria were the same as in Sample 1. Diagnoses were assessed clinically and were based on ICD-10 criteria. Primary diagnoses in terms of severity were as follows: depressive disorders (F33.0 - F33.9, $n = 35$), panic disorder with/without agoraphobia (F40.0, F41.0, $n = 11$), adjustment disorders (F43.2, $n = 12$), anxiety disorder - unspecified (F41.9, $n = 9$), posttraumatic stress disorder (F43.1, $n = 2$), generalized anxiety disorder (F41.1, $n = 2$), mixed anxiety depression (F41.2, $n = 2$), specific phobia (F40.2, $n = 2$). To achieve more robust means, Sample 1 and Sample 2 was merged for further analyses.

Measures and procedure

Sample 1 was recruited at the in-patient unit described above. The clinic is part of routine mental healthcare in Germany. About 90% of patients are referred to the clinic by a physician who works for the German pension or health insurance. The physician usually conducts unstructured clinical interviews, assigns a preliminary diagnosis, and forwards the diagnostic information to the clinic. The diagnostic process in the clinic is a systematic and standardized multistage procedure (cf. Watzke et al., 2010). In the admission phase, patients complete a comprehensive questionnaire containing psychometric measures (outlined below) and questions concerning the patient's socio-demographics, medical and psychological condition, level of functioning and well-being in various domains. Afterwards, the patient is assigned to a responsible psychotherapist who is an experienced diagnostician – a psychiatrist or psychologist who either completed a multiyear postgraduate professional training or is currently in training and works under supervision. He rediagnoses the patient based on ICD-10 symptom checklists (e.g. Hiller, Zaudig, & Mombour, 1996), data from psychometric assessment, and diagnostic information forwarded by the referring physician. Up to five diagnoses are assigned starting with the most severe to the least severe. After three weeks of therapy, initial diagnoses are reviewed for accuracy in a staff meeting by a multiprofessional team of experienced diagnosticians including the director of the unit and the responsible psychotherapist among others. Confirmation or modification of initial diagnosis is based on a

Construct validity of the ASI-3 in clinical samples

consensus decision among experts. By this systematic and standardized multistage diagnostic process – involving different experienced diagnosticians who integrate multiple data sources such as clinical interviews and psychometric measurement – a reliable diagnosis is ensured (cf. Watzke et al., 2010).

Psychometric assessment included several measures². The German adaptation (Kemper et al., 2009) of the Anxiety Sensitivity Index-3 (Taylor et al., 2007) was administered. To assess interpersonal behavior, the German adaptation (Horowitz, Strauss, & Kordy, 2000) of the Inventory of Interpersonal Problems (IIP, Horowitz, Rosenberg, Bauer, Ureno, & Vilasenor, 1988) was used. The IIP comprises the two orthogonal dimensions affiliation and dominance. The two-dimensional space is further divided into eight broad categories of interpersonal behavior (octants): PA = Domineering, BC = Vindictive, DE = Cold, FG = Socially Inhibited, HI = Submissive, JK = Exploitable, LM = Overly Nurturant, NO = Intrusive ($.36 < \alpha < .64$). Depression symptoms was measured with a German short form (ADS-K, Hautzinger & Bailer, 1993; $\alpha = .90$) of the Center of Epidemiologic Studies Depression Scale (CES-D, Radloff, 1977). The German trait version (Laux, Glanzmann, Schaffner, & Spielberger, 1981; $\alpha = .90$) of the State-Trait Anxiety Inventory (STAI, Spielberger, Gorsuch, & Lushene, 1970) was used to assess interindividual differences in anxiety. Symptom burden was assessed with the SCL-14 (Harfst et al., 2002; $\alpha = .87$), a brief German version of the Symptom Check List-90-R (SCL-90-R, Derogatis, Rickels, & Rock, 1976). To measure bodily discomfort in four different domains (exhaustion, rheumatism, abdominal pain, heart complaints) the Giessen Subjective Complaints List (GGB-24, Brähler & Scheer, 1995; $\alpha = .93$) was administered.

Participants in Sample 2 received most of the psychometric measures administered in Sample 1. They completed the ASI-3, CES-D, and the STAI. Additionally, they were asked to fill out a German adaptation (Vormbrock & Neuser, 1983; $\alpha = .83$) of the Fear of Negative Evaluation Scale (FNE, Watson & Friend, 1969) and the Body Vigilance Scale (BVS;

Construct validity of the ASI-3 in clinical samples

Schmidt, Lerew, & Trakowski, 1997; $\alpha = .83$). The FNE measures the disposition to fear potential negative evaluation by others. Fear of negative evaluation is thought to be a core cognitive factor of social anxiety and social phobia (e.g. Clark & Wells, 1995). Body vigilance, as assessed by the BVS, denotes consciously attending to internal bodily sensations and perturbations. This normally adaptive process has been found to be exaggerated in patient samples (Schmidt et al., 1997). As in Study 1, participants filled out the questionnaire before the commencement of treatment.

The study protocol described above was approved by the local human ethics committee. All patients who participated in the present research received a complete description of the study and provided written informed consent prior to data collection.

Statistical analysis

Data analysis was conducted in four steps. (1) At first, descriptive statistics for the general scale and three subscale scores of the ASI-3 as well as reliability coefficients (Cronbach α) were computed and evaluated according to Nunally and Bernstein (1994; . $\alpha > .70 =$ acceptable, $\alpha > .80 =$ good). Afterwards, several aspects of construct validity of the ASI-3 were tested.

(2) Factorial validity was investigated using a structural equation modeling approach. The three factor hierarchical model confirmed by Taylor et al. (2007) for the ASI-3 and by Kemper et al. (2009) for its German adaptation in essentially nonclinical samples was fitted to the combined clinical sample using robust maximum likelihood (MLR) estimation in MPlus 6. Model fit assessment was based on fit indices recommended by Beauducel and Wittmann (2005). These authors favor the SRMR (Standardized Root Mean Square Residual) and the RMSEA (Root Mean Square Error of Approximation) particularly with regard to latent trait models. Assessment of model fit was based on criteria proposed by Hu and Bentler (1999).

(3) Group differences in ASI-3 scores of patients diagnosed with specific mental disorders were tested according to theoretical expectations outlined above. Due to the low

Construct validity of the ASI-3 in clinical samples

frequency of some disorders in the merged sample, we formed four groups based on primary ICD-10 diagnosis – panic disorder/agoraphobia (panic disorder with or without agoraphobia), other anxiety disorder (social phobia, GAD, and PTSD), mood disorder (depressive episode and dysthymia), non-anxiety or non-mood disorder (somatoform and adjustment disorder) – to test our theoretical expectations. Only diagnoses with $n > 5$ were classified into these groups. Diagnoses that could not be classified unambiguously were excluded from the analysis, e.g. mixed anxiety-depression (F43.1).

To consider comorbidity and the potential role of the secondary diagnosis we performed analyses of variance (ANOVA) with the primary diagnosis (panic disorder/agoraphobia, other anxiety disorder, mood disorder, non-anxiety or non-mood disorder), the secondary diagnosis (no secondary diagnosis, panic disorder/agoraphobia, other anxiety disorder, mood disorder, non-anxiety or non-mood disorder, substance use disorder), and the primary diagnosis by secondary diagnosis interaction as predictors, and the relevant ASI-3 subscales as criteria. The interaction was included to reveal any contribution of specific combinations of primary and secondary diagnoses to the prediction. Because of the imbalanced design – caused by unequal cell sizes – there are different choices concerning the type of sums of squares for the ANOVAs. We used so-called Type I sums of squares, in which the contribution of the predictors in a model are tested sequentially. Because of its importance, the primary diagnosis was entered before the secondary diagnosis; the interaction was entered last. In this way it is possible to answer the question whether the secondary diagnosis adds in any way to the prediction of the ASI scores, over and above the prediction already possible by the primary diagnosis. Subsequently, follow up tests ($\alpha = .05$) were conducted and effect sizes (Hedges g ; Hedges, 1981) were calculated.

(4) Correlational analyses were conducted to further examine theoretical expectations concerning convergent and discriminant validity of the ASI-3 scales. To demonstrate the differential validity of subscales, correlation coefficients between ASI-3 subscales and

Construct validity of the ASI-3 in clinical samples

psychopathology-related measures were also tested for substantial differences with methods proposed for the comparison of correlated correlation coefficients (Meng, Rubin, & Rosenthal, 1992; Steiger, 1980).

Results

Descriptive statistics and reliability

Descriptive statistics and reliability coefficients are presented in Table 1. In Sample 1, ASI-3 total scores ranged from 0 to 72, in Sample 2 from 5 to 72, respectively. Scores for the Social Concerns subscale ranged from 0 to 24 in Sample 1 and from 1 to 24 in Sample 2, respectively. Scores for Cognitive Concerns and Somatic Concerns ranged from 0 to 24 in Sample 1 and 2 as well. Both samples showed nearly exactly the same means and standard deviations. A Multivariate Analysis of Variance (MANOVA) of the ASI-3 scales did not yield any significant differences between samples (Wilks's $\lambda = .99$, $F_{[3, 585]} = 1.79$, $p > .05$). Reliability coefficients for the ASI-3 scales ($.85 < \alpha < .92$) may be considered good according to Nunnally and Bernstein (1994).

Factorial validity

The three-factor hierarchical model of the ASI-3 is depicted in Figure 1. No exact model fit was achieved ($\chi^2 = 583.0$, $df = 133$, $p < .001$, SRMR = .07, RMSEA = .07 [.07 - .08], CFI = .90). Modification indices (MIs) were inspected to identify potential sources of model misfit. Inspection of the MIs pointed to several residual correlations within the Cognitive Concerns subscale. The three highest MIs were found for the residuals of item 2 ("When I cannot keep my mind on a task, I worry that I might be going crazy") and item 5 ("It scares me when I am unable to keep my mind on a task"), residual correlation $r = .39$; items 2 and 14 ("When my thoughts seem to speed up, I worry that I might be going crazy"), residual correlation $r = .24$; and items 16 ("When I have trouble thinking clearly, I worry that there is something wrong with me") and 18 ("When my mind goes blank, I worry that there is something terribly wrong with me"), residual correlation $r = .25$. Apparently, these correlated

Construct validity of the ASI-3 in clinical samples

residuals are not due to conceptual reasons – misspecification of the model – but to technical aspects of the ASI-3, i.e., an overlap in wording of some items. Thus, we included these residual correlations in the model, thereby yielding an acceptable fit for the three factor hierarchical model of the ASI-3 ($\chi^2 = 439.9$, $df = 130$, $p < .001$, SRMR = .05, RMSEA = .06 [.05 - .07], CFI = .94). All items had substantial loadings on their respective factors ($.49 < \lambda < .84$) and lower-order factors had high loadings on the higher-order AS factor, SOM $\lambda = .69$, SOC $\lambda = .85$, and COG $\lambda = .96$, supporting a global AS construct.

Convergent, discriminant, and criterion-related validity

Results are presented in order of the four theoretical expectations described above. (1) Group difference in GAS with respect to the primary diagnosis were substantial and highly significant ($F_{[3, 461]} = 11.16$, $p < .001$). Neither the secondary diagnosis ($F_{[5, 461]} = 0.93$, $p > .05$), nor the combination of primary and secondary diagnosis ($F_{[14, 461]} = 1.09$, $p > .05$) yielded unique contributions to this differentiation. Follow up tests showed that patients diagnosed with anxiety disorders ($N = 78$; $M = 40.68$; $SD = 15.91$) had significantly higher scores compared to those with non-anxiety disorders ($N = 406$; $M = 31.53$; $SD = 15.58$; $t_{[482]} = 4.74$, $p < .001$, Hedges $g = .58$).

(2) There was also a significant difference in SOM scores of patients ($F_{[3, 461]} = 15.12$, $p < .001$). Main effect of secondary diagnosis ($F_{[5, 461]} = 0.66$, $p > .05$) and the interaction were not significant ($F_{[14, 461]} = 1.21$, $p > .05$). Those patients diagnosed with panic disorder and/or agoraphobia ($N = 45$; $M = 14.84$; $SD = 6.50$) had significantly higher scores than those with other anxiety disorders ($N = 33$; $M = 11.12$; $SD = 7.35$; $p < .05$, Hedges $g = .52$) and those with non-anxiety disorders ($N = 406$; $M = 8.83$; $SD = 5.83$; $p < .001$, Hedges $g = .95$). The difference between patients with other anxiety disorders and those with non-anxiety disorders was not significant ($p > .05$, Hedges $g = .33$). Correlations between ASI-3 scores and different psychopathology-related measures are depicted in Table 2. As expected, SOM scores were substantively associated with measures of self-reported body vigilance ($r = .56$, p

Construct validity of the ASI-3 in clinical samples

< .01), and symptom burden (GBB, $r = .37$, $p < .01$; SCL, $r = .42$, $p < .01$). Moreover, correlations with psychopathology-related measures differed across ASI-3 subscales supporting their differential validity. For example, correlations between BVS and ASI-3 subscales were substantially higher for SOM than for COG ($t = 2.2$, $p < .05$) and SOC ($t = 2.8$, $p < .01$). Some correlations between ASI-3 subscales and measures of symptom burden were also significantly different, e.g. correlations of COG vs. SOC with psychopathology-related measures were substantially higher for GBB ($t = -4.5$, $p < .01$) and for SCL-14 ($t = -2.8$, $p < .01$). However, criterion correlations of SOM were not higher compared to SOC and COG. Thus, theoretical expectations were not met in the case of symptom burden as strongest correlations were not observed for SOM.

(3) In line with theoretical expectations from the AS literature, SOC scores were positively associated with fear of negative evaluation ($r = .66$, $p < .01$) and theoretically related IIP-octants. As expected, the highest correlation of ASI-3 subscales with FNE was observed for SOC. The correlation of SOC with FNE was substantially higher than the correlation of SOM with FNE ($t = -2.8$, $p < .01$). However, validity coefficients of SOC and COG did not differ. In Figure 2, differential associations of ASI-3 subscales and IIP-octants are presented. As expected, SOC scores were positively associated with Social Inhibition (FG, $r = .29$, $p < .01$) and Submissiveness (HI, $r = .14$, $p < .05$), and negatively associated with Domineering (PA, $r = -.28$, $p < .01$) and Intrusiveness (NO, $r = -.18$, $p < .01$). Cognitive Concerns scores also showed some minor but significant correlations with IIP-measures (highest: PA, $r = -.14$, $p < .01$). There were no significant associations of SOM scores and IIP scales.

(4) Concerning COG scores, groups substantially differed. A main effect of primary diagnosis ($F_{[3, 461]} = 5.46$, $p < .01$) but not for secondary diagnosis ($F_{[15, 461]} = 0.95$, $p > .05$) was observed. The interaction was not significant ($F_{[14, 461]} = 1.16$, $p > .05$). Confirming the theoretical expectation derived from the AS literature, patients with a diagnosis of an anxiety

Construct validity of the ASI-3 in clinical samples

or mood disorder ($N = 342$; $M = 11.99$; $SD = 6.35$) had higher COG scores compared to those not diagnosed with an anxiety or mood disorder ($N = 142$; $M = 9.57$; $SD = 6.40$; $t_{[482]} = 3.81$, $p < .001$; Hedges $g = .38$). COG was also correlated with depression symptoms as expected ($r = .36$, $p < .01$). Moreover, this correlation with the CES-D was substantially higher for COG compared to SOM ($t = -4.5$, $p < .01$) and SOC ($t = -2.5$, $p < .05$) supporting differential validity of the ASI-3 subscales.

Besides statistical associations pertaining to the theoretical expectations reported above, further results concerning the GAS score seem noteworthy. GAS correlated substantially with diverse measures of psychopathology-related constructs. Strong correlations were observed with FNE, STAI, SCL-14, and BVS. Correlations of medium size were observed with CES-D and GBB-24.

Discussion

As indicated by prior research, the recently developed ASI-3 seems a promising candidate for a standard assessment tool in AS research. However, results concerning the construct validity of the ASI-3 in clinical samples are still sparse. In the study presented here, we sought to find comprehensive evidence on the usefulness of the ASI-3 in clinical psychology research and applied settings. To this purpose, different aspects of the construct validity of the ASI-3 was tested in two clinical samples. The three-factorial structure of the ASI-3 found in nonclinical student samples was corroborated in a sample of patients with primary diagnosis of anxiety or mood disorder. The subscale scores of the measure showed different patterns of statistical relations with clinical diagnosis of mental disorders, interpersonal functioning, body vigilance, as well as symptom burden which are consistent with AS literature. These results will be addressed in further detail below.

Because the structure of the ASI-3 had been established in previous studies, we applied a confirmatory approach to test the factorial validity of the ASI-3. The three factor model proposed by Taylor et al. (2007) yielded an acceptable fit to the data. All items had

Construct validity of the ASI-3 in clinical samples

high and substantial loadings on three substantially correlated factors which measure somatic, social, and cognitive concerns about anxiety-related sensations. Correlations among factors were high and consistent with previous AS research (cf. Taylor et al., 2007, Study 2) thereby supporting a global AS construct. An objection some researchers might have concerning model fit relates to residual correlations of items within the Cognitive Concerns factor. However, these residual correlations were due to an overlap in item wording rather than due to conceptual reasons. They do not contradict the factorial validity of the ASI-3. Since residual correlations were not observed before, assuming sample specific influences seems reasonable in this case. Our results are in line with results from the initial validation study of Taylor et al. (2007) and a validation study of the German adaptation (Kemper et al., 2009). Results presented by these authors support a three factor hierarchic structure for nonclinical samples from North America, Spain, Mexico, France, the Netherlands, and Germany. According to our results, the three-factor hierarchic structure of the ASI-3 seems to apply to clinical samples as well.

Further evidence supporting the construct validity of the ASI-3 in clinical samples was gathered. We examined mean differences in ASI-3 scores between patients differing in clinical diagnosis and correlations between ASI-3 scales and other psychopathology-related constructs. Our pattern of results was highly consistent with findings from AS research. Global AS scores of patients allowed for a differentiation of patients with and without anxiety disorder diagnosis (cf. Deacon & Abramowitz, 2006; Olatunji & Wolitzky-Taylor, 2009; Reiss et al., 1986). Furthermore, the Global AS score showed a pattern of relations to other constructs well known from the AS literature. Highest correlations were observed with measures of anxiety and lower but still substantial correlations emerged with measures of body vigilance, symptom burden, and interpersonal functioning (cf. Armstrong et al., 2006; Deacon & Abramowitz, 2006; Naragon-Gainey, 2010; Zvolensky & Forsyth, 2002). For ASI-3 subscales, expectations derived from the AS literature were also met. The Somatic Concerns

Construct validity of the ASI-3 in clinical samples

subscale allowed for the differentiation of patients with panic disorder and/or agoraphobia from patients with other anxiety disorders or non-anxiety disorders (cf. Reiss et al., 1986; Taylor et al., 2007) and subscale scores correlated with measures of body vigilance and symptom burden (cf. Asmundson, Frombach, & Hadjistavropoulos, 1998; Osman et al., 2010; Richards & Bertram, 2000; Zvolensky & Forsyth, 2002). For the Social Concerns subscale which captures the fear of publicly observable anxiety reactions, substantial correlations with fear of negative evaluation and interpersonal behavior – IIP octants – emerged as expected. We found convergent correlations for octants measuring shy, insecure, introverted, or socially avoidant behavior and discriminant correlations for octants measuring outgoing, assertive, or dominant behavior (cf. Cox, Borger, Taylor, Fuentes, & Ross, 1999; Deacon & Abramowitz, 2006). Concerning ASI-3 Cognitive Concerns, theoretical expectations derived from the AS literature were met as well. As expected, scores of patients with vs. without an anxiety or mood disorder differed substantially in Cognitive Concerns (cf. Taylor et al., 2007) and subscale scores were substantially related to depression symptoms (cf. Naragon-Gainey, 2010; Osman et al., 2010; Otto et al., 1995).

Adding to the construct validity of the ASI-3 is the fact that different correlations with psychopathology-related constructs were found for ASI-3 subscales. For example, Somatic Concerns seems specifically related to vigilance for somatic symptoms. Correlation of this subscale with body vigilance was substantially higher compared to other ASI-3 subscales. Evidence for differential validity emerged with measures of symptom burden as well. But contrary to expectations, highest correlations were not observed with Somatic Concerns but with Cognitive Concerns. However, this unexpected finding may rather be due to an inappropriate expectation in the first place rather than a lack of validity of the Somatic Concerns subscale. Further evidence suggests differential validity of ASI-3 subscales. Social Concerns seems specifically related to fear of negative evaluation and thematically relevant IIP octants. Concerning Cognitive Concerns, highest and substantially different correlations

Construct validity of the ASI-3 in clinical samples

were observed with depression symptoms compared to correlations with other subscales.

Taken together, we gathered considerable evidence supporting the construct validity of the ASI-3 by replicating (a) the three-factor hierarchic structure proposed by Taylor and colleagues (2007), (b) statistical associations of the ASI-3 scales with different psychopathology-related constructs reported in previous AS research, as well as (c) differences in ASI-3 subscale scores of patients differing in primary clinical diagnosis while controlling for possible effects of comorbidity.

A limiting factor of the present research was sample size. In future studies on the usefulness of the ASI-3 in clinical psychology research and practice a larger sample size is preferable. In the research presented here, patients with certain disorders were undersampled, e.g. patients with social phobia, generalized anxiety disorder, posttraumatic stress disorder, or hypochondriasis. Thus, differences in ASI-3 subscale scores for these groups of patients could not be tested. Furthermore, reference scores for patients with different anxiety or mood disorders are necessary for clinical assessment procedures. These scores should be sufficiently stable, i.e., calculated from a large sample.

Due to these limitations, our study can only be seen as an important first step in testing the construct validity of the ASI-3 in clinical samples. To establish the ASI-3 as a useful and appropriate assessment tool in clinical psychology research and practice, an extension of our work is highly encouraged.

References

- Armstrong, K. A., Khawaja, N. G., & Oei, T. P. S. (2006). Confirmatory factor analysis and psychometric properties of the Anxiety Sensitivity Index-Revised in clinical and normative populations. *European Psychologist, 22*(2), 116–125. doi: 10.1027/1015-5759.22.2.116
- Asmundson, G. J., Frombach, I. K., & Hadjistavropoulos, H. D. (1998). Anxiety sensitivity: Assessing factor structure and relationship to multidimensional aspects of pain in injured workers. *Journal of Occupational Rehabilitation, 8*(3), 223–234. doi: 10.1023/A:1021382624491
- Asmundson, G. J. G., Weeks, J. W., Carleton, R. N., Thibodeau, M. A., & Fetzner, M. G. (2011). Revisiting the latent structure of the anxiety sensitivity construct: more evidence of dimensionality. *Journal of Anxiety Disorders, 25*, 138–147. doi:10.1016/j.janxdis.2010.08.013
- Beauducel, A., & Wittmann, W. W. (2005). Simulation study on fit indexes in CFA based on data with slightly distorted simple structure. *Structural Equation Modeling, 12*(1), 41–75. doi: 10.1207/s15328007sem1201_3
- Bernstein, A., Stickle, T. R., Zvolensky, M. J., Taylor, S., Abramowitz, J., & Stewart, S. (2010). Dimensional, categorical, or dimensional-categories: Testing the latent structure of anxiety sensitivity among adults using factor-mixture modeling. *Behavior Therapy, 41*(4), 515-529. doi:10.1016/j.beth.2010.02.003
- Bernstein, A., Zvolensky, M. J., Norton, P. J., Schmidt, N. B., Taylor, S., Forsyth, J. P., Lewis, S. F., Feldner, M. T., Leen-Feldner, E. W., Stewart, S. H., & Cox, B. (2007). Taxometric and factor analytic models of anxiety sensitivity: Integrating approaches to latent structural research. *Psychological Assessment, 19*(1), 74–87. doi: 10.1037/1040-3590.19.1.74

Construct validity of the ASI-3 in clinical samples

Brähler, E., & Scheer, J. W. (1995): *Der Giessener Beschwerdebogen. Handbuch* [Giessen Subjective Complaints List]. Bern: Huber.

Broman-Fulks, J. J., Green, B. A., Berman, M. E., Olatunji, B. O., Arnau, R. C., Deacon, B. J., & Sawchuk, C. N. (2008). The latent structure of anxiety sensitivity - Revisited. *Assessment, 15*(2), 188–203. doi: 10.1177/1073191107311284

Broman-Fulks, J. J., Deacon, B. J., Olatunji, B. O., Bondy, C. L., Abramowitz, J. S., & Tolin, D. F. (2010). Categorical or dimensional: a reanalysis of the Anxiety Sensitivity construct. *Behavior Therapy, 41*(2), 154–171. doi:10.1016/j.beth.2009.02.005

Calamari, J. E., Rector, N. A., Woodard, J. L., Cohen, R. J., & Chik, H. M. (2008). Anxiety sensitivity and obsessive-compulsive disorder. *Assessment, 15* (3). doi:10.1177/1073191107312611

Clark, D. M., & Wells, A. (1995). A cognitive model of social phobia. In R. G. Heimberg, M. R. Liebowitz, D. A. Hope & F. R. Schneier (Eds.), *Social phobia: diagnosis, assessment, and treatment* (pp. 69–93). New York: Guilford Press.

Cohen, J. (1988). *Statistical power analysis for the behavioral sciences*. Hillsdale: Erlbaum.

Cox, B. J., Borger, S. C., Taylor, S., Fuentes, K., & Ross, L. M. (1999). Anxiety sensitivity and the five-factor model of personality. *Behaviour Research and Therapy, 37*(7), 633–641. doi: 10.1016/S0005-7967(98)00174-0

Deacon, B., & Abramowitz, J. (2006). Anxiety sensitivity and its dimensions across the anxiety disorders. *Journal of Anxiety Disorders, 20*(7), 837–857. doi: 10.1016/j.janxdis.2006.01.003

Derogatis, L. R., Rickels, K., & Rock, A. (1976). The SCL-90 and the MMPI: a step in the validation of a new self-report scale. *British Journal of Psychiatry, 128*, 280–290. doi: 10.1192/bjp.128.3.280

Construct validity of the ASI-3 in clinical samples

Eifert, G. H., Zvolensky, M. J., Sorrell, J. T., Hopko, D. R., & Lejuez, C. W. (1999).

Predictors of self-reported anxiety and panic symptoms: An evaluation of anxiety sensitivity, suffocation fear, heart-focused anxiety, and breath-holding duration. *Journal of Psychopathology and Behavioral Assessment*, 21(4), 293–305. doi: 10.1023/A:1022116731279

Hautzinger, M., & Bailer, M. (1993). *Allgemeine Depressions Skala* [German version of the Center of Epidemiologic Studies Depression Scale (CES-D)]. Weinheim: Beltz Test.

Harfst, T., Koch, U., Kurtz von Aschoff, C., Nutzinger, D. O., Rüdell, H., & Schulz, H. (2002). Entwicklung und Validierung einer Kurzform der Symptom Checklist-90-R [Development and validation of a short version of the Symptom Check List-90 (SCL-90)]. *DRV-Schriften*, 3, 71-73.

Hedges, L.V. (1981). Distribution theory for Glass's estimator of effect size and related estimators. *Journal of Educational Statistics*, 6, 107–128. doi: 10.2307/1164588

Hiller, W., Zaudig, M., & Mombour, W. (1996). *IDCL - International Diagnostic Checklists for ICD-10 and DSM-IV (Manual and 32 checklists as part of the WHO ICD-10-Checklists package)*. Seattle: Hogrefe and Huber Publishers.

Horowitz, L.M., Rosenberg, S., Baer, B., Ureno, G., & Villasenor, V. (1988). Inventory of interpersonal problems: Psychometric properties and clinical applications. *Journal of Consulting and Clinical Psychology*, 56 (6), 885–892. doi: 10.1037/0022-006X.56.6.885

Hu, L. T., & Bentler, P. M. (1999). Cutoff criteria for fit indexes in covariance structure analysis: Conventional criteria versus new alternatives. *Structural Equation Modeling*, 6, 1-55. doi: 10.1080/10705519909540118

Construct validity of the ASI-3 in clinical samples

Horowitz, L. M., Strauß, B. & Kordy, H. (2000). *Inventar zur Erfassung Interpersonaler Probleme IIP* [German version of the Inventory of Interpersonal Problems (IIP-C)].

Göttingen: Beltz Test.

Jacobi, F., Wittchen, H. U., Holting, C., Höfler, M., Pfister, H., Müller, N., & Lieb, R. (2004).

Prevalence, co-morbidity and correlates of mental disorders in the general population: results from the German Health Interview and Examination Survey (GHS). *Psychological Medicine*, 34(4), 597–611. doi: 10.1017/S0033291703001399

Kemper, C. J., Ziegler, M., & Taylor, S. (2009). Überprüfung der psychometrischen Qualität der deutschen Version des Angstsensitivitätsindex-3. *Diagnostica*, 55(4), 223–233.

Kemper, C. J. (2010). *Das Persönlichkeitsmerkmal Angstsensitivität: Taxon oder Dimension? - Eine Analyse mit dem Mischverteilungs-Raschmodell*. Hamburg: Dr. Kovac.

Laux, L., Glanzmann, P., Schaffner, P., & Spielberger, C. D. (1981). *Das State-Trait-Angstinventar (STAI). Theoretische Grundlagen und Handanweisung* [German version of the State Trait Anxiety Inventory (STAI)]. Weinheim: Beltz Test.

Leen-Feldner, E. W., Feldner, M. T., Reardon, L. E., Babson, K. A., & Dixon, L. (2008).

Anxiety sensitivity and posttraumatic stress among traumatic event-exposed youth. *Behaviour Research and Therapy*, 46(4), 548-556. doi:10.1016/j.brat.2008.01.014.

Meng, X.-L., Rosenthal, R., & Rubin, D. B. (1992). Comparing correlated correlation coefficients. *Psychological Bulletin*, 111, 172-175. doi: 10.1037/0033-2909.111.1.172

Muthen, B. (2008). Latent variable hybrids: Overview of old and new models. In G. R. Hancock & K. M. Samuelsen (Eds.), *Advances in latent variable mixture models* (pp. 1-24). Charlotte, NC: Information Age.

Naragon-Gainey, K. (2010). Meta-analysis of the relations of anxiety sensitivity to the depressive and anxiety disorders. *Psychological Bulletin*, 136(1), 128–150. doi:

10.1037/a0018055

Construct validity of the ASI-3 in clinical samples

Nolen-Hoeksema, S. (2000). The role of rumination in depressive disorders and mixed anxiety/depressive symptoms. *Journal of Abnormal Psychology, 109*(3), 504–511. doi: 10.1037/0021-843X.109.3.504

Nunnally, J. C., & Bernstein, I. H. (1994). *Psychometric theory*. New York: McGraw-Hill.

Olatunji, B. O., & Wolitzky-Taylor, K. B. (2009). Anxiety sensitivity and the anxiety disorders: A meta-analytic review and synthesis. *Psychological Bulletin, 135*(6), 974–999. doi: 10.1037/a0017428

Osman, A., Gutierrez, P. M., Smith, K., Qijuan Fang, Lozano, G., & Devine, A. (2010). The Anxiety Sensitivity Index-3: Analyses of Dimensions, Reliability Estimates, and Correlates in Nonclinical Samples. *Journal of Personality Assessment, 92*(1), 45–52. doi: 10.1080/00223890903379332

Otto, M. W., Pollack, M. H., Fava, M., Uccello, R., & Rosenbaum, J. F. (1995). Elevated Anxiety Sensitivity Index scores in patients with major depression: Correlates and changes with antidepressant treatment. *Journal of Anxiety Disorders, 9*(2), 117–123. doi: 10.1016/0887-6185(94)00035-2

Peterson, R. A., & Plehn, K. (1999). Measuring anxiety sensitivity. In S. Taylor (Ed.), *Anxiety sensitivity - Theory, research, and treatment of the fear of anxiety* (pp. 61–82). Mahwah: Erlbaum.

Plehn, K., & Peterson, R. A. (2002). Anxiety sensitivity as a predictor of the development of panic symptoms, panic attacks, and panic disorder: A prospective study. *Journal of Anxiety Disorders, 16*(4), 455–474. doi: 10.1016/S0887-6185(02)00129-9

Radloff, L. S. (1977). The CES-D Scale: A self-report depression scale for research in the general population. *Applied Psychological Measurement, 1*(3), 385–401. doi: 10.1177/014662167700100306

Construct validity of the ASI-3 in clinical samples

Rector, N. A., Szacun-Shimizu, K., & Leybman, M. (2007). Anxiety sensitivity within the anxiety disorders: disorder-specific sensitivities and depression comorbidity. *Behaviour Research and Therapy*, *45*, 1967–1975. doi:10.1016/j.brat.2006.09.017

Reiss, S. (1991). Expectancy model of fear, anxiety, and panic. *Clinical Psychology Review*, *11*(2), 141–153. doi: 10.1016/0272-7358(91)90092-9

Reiss, S., Peterson, R. A., Gursky, D. M., & McNally, R. J. (1986). Anxiety sensitivity, anxiety frequency and the prediction of fearfulness. *Behaviour Research and Therapy*, *24*(1), 1–8. doi: 10.1016/0005-7967(86)90143-9

Steiger, J.H. (1980). Tests for comparing elements of a correlation matrix. *Psychological Bulletin*, *87*, 245–251. doi: 10.1037/0033-2909.87.2.245

Richards, J. C., & Bertram, S. (2000). Anxiety sensitivity, state and trait anxiety, and perception of change in sympathetic nervous system arousal. *Journal of Anxiety Disorders*, *14*(4), 413–427. doi: 10.1016/S0887-6185(00)00031-1

Sandin, B., Chorot, P., & McNally, R. J. (1996). Validation of the spanish version of the Anxiety Sensitivity Index in a clinical sample. *Behaviour Research and Therapy*, *34*(3), 283–290. doi: 10.1016/0005-7967(95)00074-7

Schmidt, N. B. (1999). Prospective evaluation of anxiety sensitivity. In S. Taylor (Ed.), *Anxiety sensitivity - Theory, research, and treatment of the fear of anxiety* (pp. 61–82). Mahwah: Erlbaum.

Schmidt, N. B., Eggleston, A. M., Woolaway-Bickel, K., Fitzpatrick, K. K., Vasey, M. W., & Richey, J. A. (2007). Anxiety Sensitivity Amelioration Training (ASAT): A longitudinal primary prevention program targeting cognitive vulnerability. *Journal of Anxiety Disorders*, *21*(3), 302–319. doi: 10.1016/j.janxdis.2006.06.002

Schmidt, N. B., Keough, M. E., Mitchell, M. A., Reynolds, E. K., MacPherson, L., Zvolensky, M. J., & Lejuez, C. W. (2010). Anxiety sensitivity: Prospective prediction of

Construct validity of the ASI-3 in clinical samples

anxiety among early adolescents. *Journal of Anxiety Disorders*, 24(5), 503–508. doi:
10.1016/j.janxdis.2010.03.007

Schmidt, N. B., Lerew, D. R., & Trakowski, J. H. (1997). Body vigilance in Panic Disorder:
Evaluating attention to bodily perturbations. *Journal of Consulting and Clinical
Psychology*, 65(2), 214-220. doi: 10.1037/0022-006X.65.2.214

Schmidt, N. B., & Mallott, M. (2006). Evaluating anxiety sensitivity and other fundamental
sensitivities predicting anxiety symptoms and fearful responding to a biological challenge.
Behaviour Research and Therapy, 44(11), 1681–1688. doi:10.1016/j.brat.2005.12.001.

Schmidt, N. B., Zvolensky, M. J., & Maner, J. K. (2006). Anxiety sensitivity: Prospective
prediction of panic attacks and Axis I pathology. *Journal of Psychiatric Research*, 40(8),
691–699. doi: 10.1016/j.jpsychires.2006.07.009

Spielberger, C. D., Gorsuch, R. C., & Lushene, R. E. (1970). *Manual for the State Trait
Anxiety Inventory*. Palo Alto, CA: Consulting Psychologists Press.

Taylor, S. (1996). Nature and measurement of anxiety sensitivity: Reply to Lilienfeld, Turner,
and Jacob (1996). *Journal of Anxiety Disorders*, 10(5), 425–451. doi: 10.1016/0887-
6185(96)00021-7

Taylor, S. (Ed.) (1999). *Anxiety sensitivity - Theory, research, and treatment of the fear of
anxiety*. Mahwah: Erlbaum.

Taylor, S., & Cox, B. J. (1998). An expanded anxiety sensitivity index: Evidence for a
hierarchical structure in a clinical sample. *Journal of Anxiety Disorders*, 12(5), 463–483. doi:
10.1016/S0887-6185(98)00028-0

Taylor, S., Koch, W. J., Woody, S., & McLean, P. (1996). Anxiety sensitivity and depression:
How are they related? *Journal of Abnormal Psychology*, 105(3), 474–479. doi:
10.1037/0021-843X.105.3.474

Construct validity of the ASI-3 in clinical samples

Taylor, S., Zvolensky, M. J., Cox, B. J., Deacon, B., Heimberg, R. G., Ledley, D. R., et al.

(2007). Robust dimensions of anxiety sensitivity: Development and initial validation of the Anxiety Sensitivity Index-3. *Psychological Assessment, 19*(2), 176–188. doi: 10.1037/1040-3590.19.2.176

Vormbrock, F., & Neuser, J. (1983). Konstruktion zweier spezifischer Fragebögen zur Erfassung von Angst in sozialen Situationen (SANB und SVSS) [German version of the Fear of Negative Evaluation Scale (FNE)]. *Diagnostica, 29*, 165–182.

Waller, N. G., & Meehl, P. E. (1998). *Multivariate taxometric procedures: Distinguishing types from continua*. Thousand Oaks: Sage.

Watson, D., & Friend, R. (1969). Measurement of social-evaluative anxiety. *Journal of Consulting and Clinical Psychology, 33*(4), 448–457. doi: 10.1037/h0027806

Watzke, B., Ruddel, H., Jurgensen, R., Koch, U., Kriston, L., Grothgar, B., & Schulz, H. (2010). Effectiveness of systematic treatment selection for psychodynamic and cognitive-behavioural therapy: randomised controlled trial in routine mental healthcare. *The British Journal of Psychiatry, 197*(2), 96-105. doi: 10.1192/bjp.bp.109.072835.

World Health Organization. (1992). *The ICD-10 Classification of Mental and Behavioural Disorders – Clinical Descriptions and Diagnostic Guidelines*. Geneva: World Health Organization.

Wilson, K. A., & Hayward, C. (2006). Unique contributions of anxiety sensitivity to avoidance: A prospective study in adolescents. *Behaviour Research and Therapy, 44*(4), 601–609. doi: 10.1016/j.brat.2005.04.005

Zinbarg, R. E., Barlow, D. H., & Brown, T. A. (1997). Hierarchical structure and general factor saturation of the Anxiety Sensitivity Index: Evidence and implications. *Psychological Assessment, 9*(3), 277–284. doi:10.1037/1040-3590.9.3.277

Construct validity of the ASI-3 in clinical samples

Zinbarg, R. E., Brown, T. A., Barlow, D. H., & Rapee, R. M. (2001). Anxiety sensitivity, panic, and depressed mood: A reanalysis teasing apart the contributions of the two levels in the hierarchical structure of the Anxiety Sensitivity Index. *Journal of Abnormal Psychology, 110*(3), 372–377. doi: 10.1037/0021-843X.110.3.372

Zvolensky, M. J., & Forsyth, J. P. (2002). Anxiety sensitivity dimensions in the prediction of body vigilance and emotional avoidance. *Cognitive Therapy and Research, 26*(4), 449–460. doi: 10.1023/A:1016223716132

Footnotes

1) Relevance for treatment means that if a medical condition (e.g. heart disease) and a mental disorder (e.g. GAD) co-occur, the mental disorder was considered as relevant to psychotherapeutic treatment.

2) Reliability coefficients (Cronbach α) for measures used in the validation process could not be calculated in Sample 1. The clinic provided only a reduced data set without item level data due to data privacy protection. Thus, we report α coefficients for each measure from the literature – based on the initial validation samples of the measures.

Construct validity of the ASI-3 in clinical samples

Table 1

Descriptive Statistics and Reliability Coefficients for ASI-3 Scales

	Sample 1 (N = 514)			Sample 2 (N = 75)		
	<i>M</i>	<i>SD</i>	<i>α</i>	<i>M</i>	<i>SD</i>	<i>α</i>
GAS	33.05	15.81	.92	33.81	15.84	.92
SOM	9.74	6.20	.88	9.69	6.61	.89
SOC	12.09	5.93	.83	13.05	6.19	.85
COG	11.22	6.39	.88	11.07	6.36	.89

Note. GAS = Global Anxiety Sensitivity; SOM = Somatic Concerns; SOC = Social Concerns; COG = Cognitive Concerns. α = Cronbach α .

Table 2

Convergent and Discriminant Validity Coefficients of ASI-3 Scales

	BVS ¹	CES-D ²	STAI ²	FNE ¹	GBB-24 ²	SCL-14 ²
GAS	.47	.34	.61	.64	.42	.53
SOM	.56	.21	.41	.38	.37	.42
SOC	.26	.29	.55	.66	.28	.43
COG	.33	.36	.59	.57	.42	.51

Note. ¹ $N = 75$; ² $N = 512 - 589$; GAS = Global Anxiety Sensitivity; SOM = Somatic Concerns; SOC = Social Concerns; COG = Cognitive Concerns; BVS = Body Vigilance Scale; CES-D = Center of Epidemiologic Studies Depression Scale; STAI = State-Trait Anxiety Inventory; FNE = Fear of Negative Evaluation Scale; GBB-24 = Giessen Subjective Complaints List; SCL-14 = Symptom Check List. All correlations are significant with $p < .01$ except for SOC and BVS ($p < .05$).

Construct validity of the ASI-3 in clinical samples

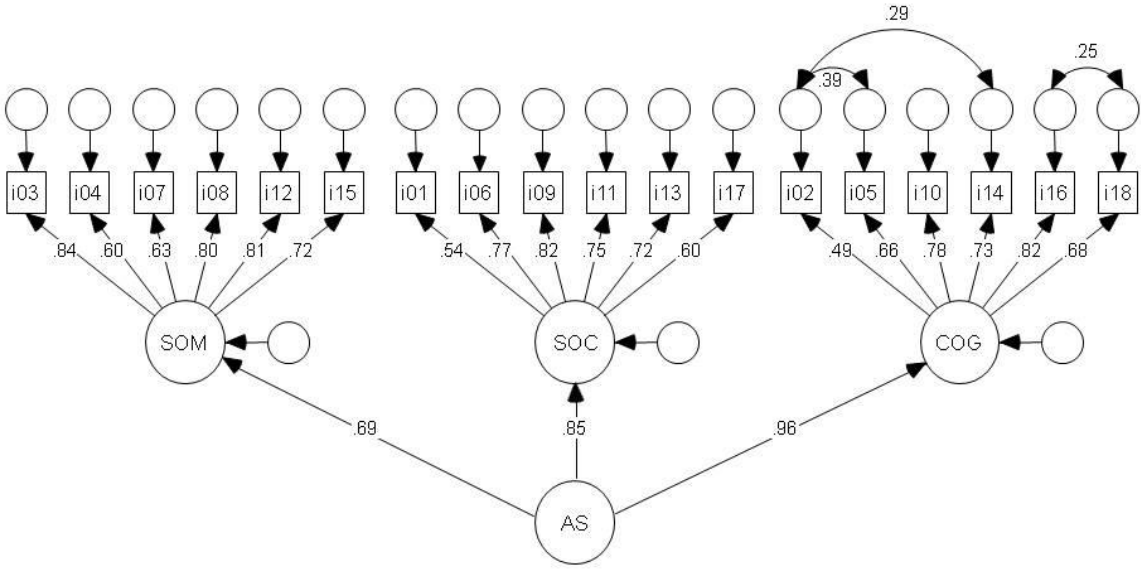

Figure 1. Model of the ASI-3 in the combined clinical sample.

Construct validity of the ASI-3 in clinical samples

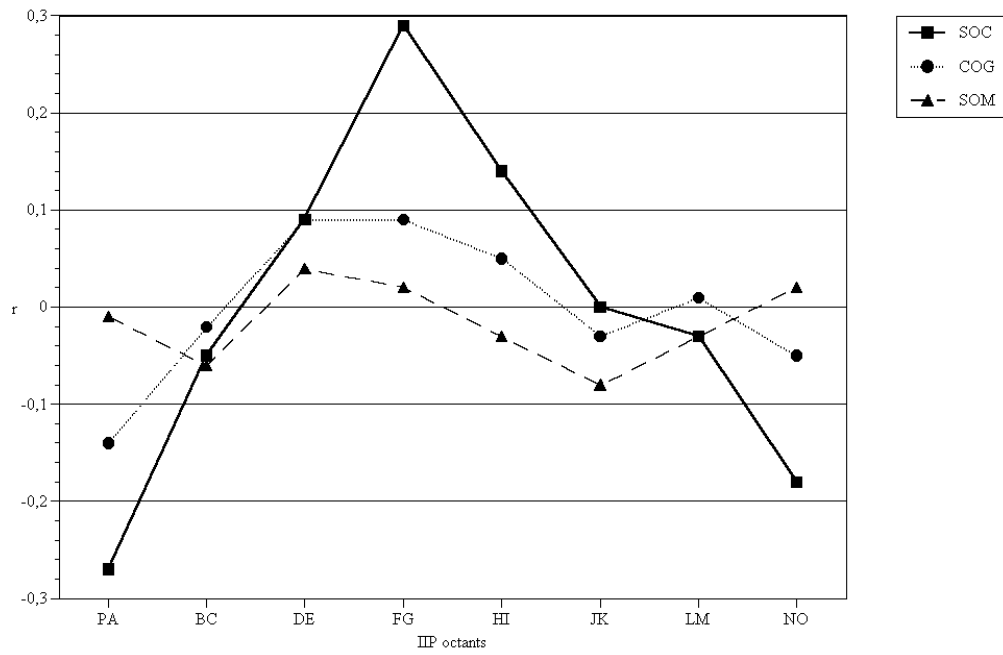

Figure 2. Correlations between ASI-3 subscales and IIP octants (PA = Domineering; BC = Vindictive; DE = Cold; FG = Socially Inhibited; HI = Submissive; JK = Exploitable; LM = Overly Nurturant; NO = Intrusive)